

Dec. 20, 1949

C. G. BEARCE

2,491,600

FRAME FOR ARTISTS' CANVAS WITH EXPANDERS

Filed April 14, 1947

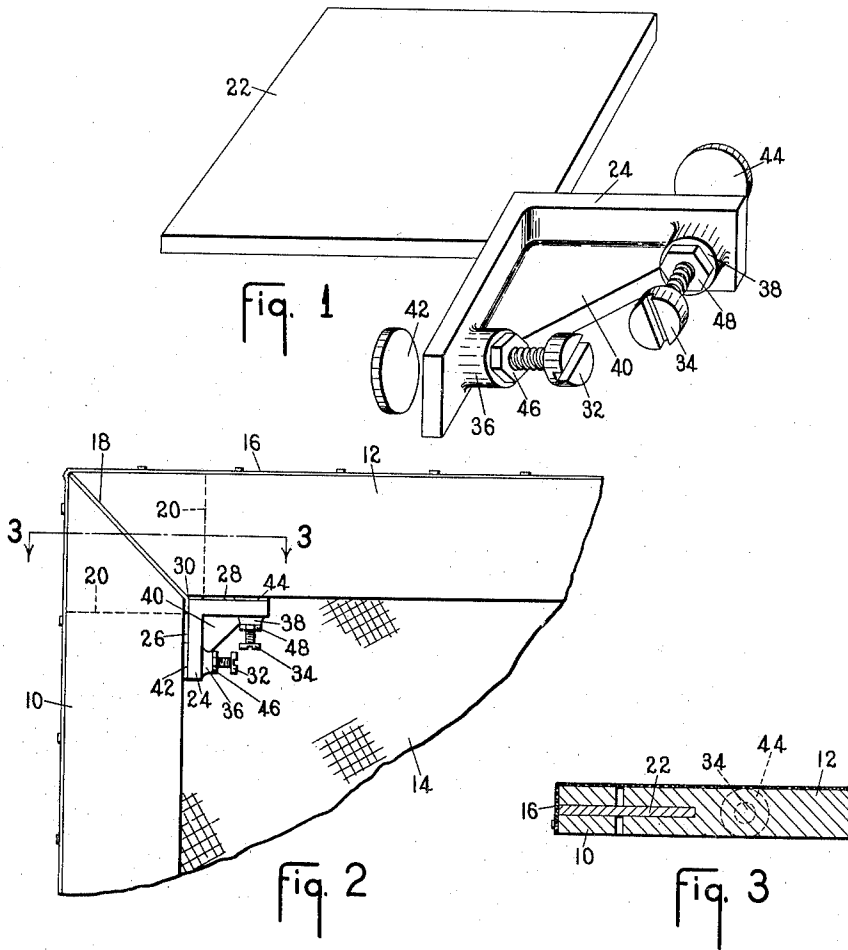

INVENTOR.  
Charles G. Bearce  
BY Wright, Brown,  
Quincy & May Attys

# UNITED STATES PATENT OFFICE

2,491,600

## FRAME FOR ARTISTS' CANVASES WITH EXPANDERS

Charles Gordon Bearce, Melrose, Mass.

Application April 14, 1947, Serial No. 741,213

4 Claims. (Cl. 45—130)

1

This invention relates to a device for expanding frames such as those on which canvas is secured for the making of oil paintings, and to a frame equipped with such devices.

Canvas on which oil paintings are to be made is customarily stretched across a rectangular wooden frame, the canvas being tacked to the exterior edge of the frame. In order to stretch the canvas with an adequate even tension, various devices have been employed to expand the frame after the canvas has been tacked on; one commonly used device being the provision of slots in the corners of the frame and the insertion of wedges into the slots. While such devices are effective for a time, the wedges are apt to shrink and fall out of the slots, leaving the canvas slack.

According to the present invention, corner devices are provided to be built into the corners of a frame, these devices having means adjustable to press the frame members outward to any desired degree and to hold their adjusted position permanently or until further adjustment is made.

For a more complete understanding of the invention, reference may be had to the following description thereof, and to the drawing, of which:

Figure 1 is an isometric view of an expanding device embodying the invention;

Figure 2 is a fragmentary rear view of a corner portion of a frame for artists' canvas showing a device installed thereon;

Figure 3 is a sectional view on the line 3—3 of Figure 2.

A corner of an artist's frame is illustrated in Figure 2, such frame being composed of four wooden frame members, portions of two of such members being indicated at 10 and 12. The four members are arranged in the form of a rectangle and a piece of canvas 14 is laid across the front face of the rectangle, the margins of the canvas being tacked to the outer edges of the frame members as at 16. As indicated in Figure 2, the ends of the frame members are customarily mitered to form a miter joint as at 18, but a square joint can be made if preferred. In either case the end portion of each frame member is longitudinally slotted from the end edge to a depth indicated by dotted line 20. These end slots are parallel to the faces of the frame members and usually receive a wooden fillet in the form of a thin rectangular piece which fits into the slots at a corner of the frame.

According to the present invention, an expand-

2

ing device is provided having a fillet portion 22 which is in the form of a flat plate. This plate is preferably but not necessarily square and is adapted to fit in the slots in the ends of the frame members forming the joint at a corner. Integral with the fillet portion 22 is an angle piece portion 24 which projects from a corner of the fillet portion 22 and is adapted to fit within an inner corner of the wooden frame when the fillet portion 22 is fitted in the slots as indicated in Figure 2. The angle portion 24 has two faces 26 and 28 which are at right angles to each other, both faces being perpendicular to the plane of the fillet portion 22. The faces 26 and 28 preferably intersect each other as at 30, the intersection being a short distance inward from the rectangular boundaries of the fillet portion 22. A pair of set screws 32 and 34 are threaded through the angle portion 24 so as to project perpendicularly from the faces 26 and 28 respectively. In order to provide an ample threaded surface for engagement with the set screws, the angle portion 24 may be provided with suitable bosses 36 and 38 through which the screws 32 and 34 extend. As indicated in Figures 1 and 3, the plane of the fillet 22 is midway between the parallel planes defined by the side edges of the angle portion 24 and contains the axes of the screws 32 and 34. The screws are arranged to engage the inner edges of the frame members 10 and 12 when they are advanced. This forces the frame members outwardly to expand the rectangle of the frame itself, the reaction to the thrust of the screws being taken by the edges of the fillet portion 22 which bear against the bottoms 20 of the slots in the frame members. In order to reinforce the angle portion 24 of the expander, a diagonal strut or web 40 may be formed between the elements having the faces 26 and 28.

Between the ends of the screws 32 and 34 and the opposite edges of the frame members, thrust plates 42 and 44 may be inserted. These plates may be in the form of metal discs adapted to distribute the pressure of the ends of the screws and thus to prevent the ends of the screws from digging into the wood of the frame members. If preferred, the thrust elements 42 and 44 can be made integral with the screws or may be permanently attached to the ends thereof. As shown in Figure 1, however, the thrust members are separate pieces.

Lock nuts 46 and 48 may be provided on the set screws to prevent the screws from working loose. It is evident that after the initial adjustment of screws to provide the desired tension on

3

the canvas, further adjustments may be made at any time thereafter to change the tension as may be desired.

Various modifications and changes may be made in the details of the structure herein shown and described without departing from the scope of the invention as defined in the following claims.

I claim:

1. A device for expanding rectangular frames, comprising a rigid member having a portion in the form of an angle piece with outer faces intersecting at right angles to each other, set screws threaded through said angle piece to project from said faces respectively, and a flat fillet portion extending outward from the intersection of said faces in a plane containing the axes of said set screws and perpendicular to the planes of said faces.

2. A device for expanding rectangular frames, comprising a rigid member having a portion in the form of an angle piece with two outer faces intersecting to form a right angle, a square fillet portion projecting from the intersection of said faces and in a plane perpendicular to both said faces, said intersection being near a corner of said square fillet and inset from the adjacent edges thereof, and set screws threaded through said angle piece to project from each said face.

3. A device for expanding rectangular frames, comprising a rigid member having a portion in the form of an angle piece with outer faces intersecting at right angles to each other and a reinforcing web across the angle, set screws threaded through said angle piece to project from said faces respectively, and a flat fillet portion extending from the intersection of said faces in

4

a plane which is perpendicular to the planes of said faces and which contains the axes of said set screws.

4. An artist's frame for canvas, comprising four frame members arranged to form a rectangle, each said member having a deep slot in its end portion extending in from the edge and parallel to the side faces of the member, and a set of expanding devices within the corners of the rectangle, each device comprising a rigid member having a fillet portion fitted into the slots of the adjacent end portions of said frame members and an angle portion integral with the fillet, said angle portion having mutually perpendicular faces adapted to fit against the inner edges of the adjacent frame members, set screws threaded through said angle portion to project from said faces in the plane of said fillet, a locking nut on each said set screw, and a flat thrust element between each set screw and the portion of the frame edge in line therewith.

CHARLES GORDON BEARCE.

#### REFERENCES CITED

The following references are of record in the file of this patent:

#### UNITED STATES PATENTS

Number	Name	Date
1,562,153	Elbern	Nov. 17, 1925
2,149,935	Tepper	Mar. 7, 1939
2,292,356	Belanger	Aug. 11, 1942

#### FOREIGN PATENTS

Number	Country	Date
122,640	Germany	July 31, 1901